

## reflecta Plano Flat 37-05 (silver) und 37-05B (black)

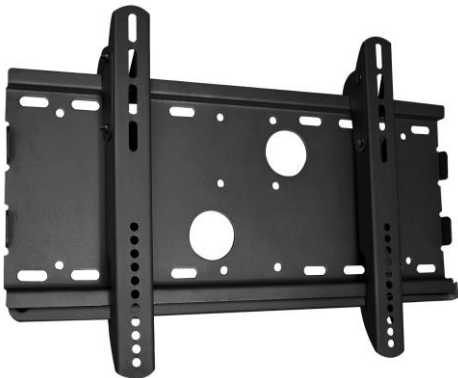
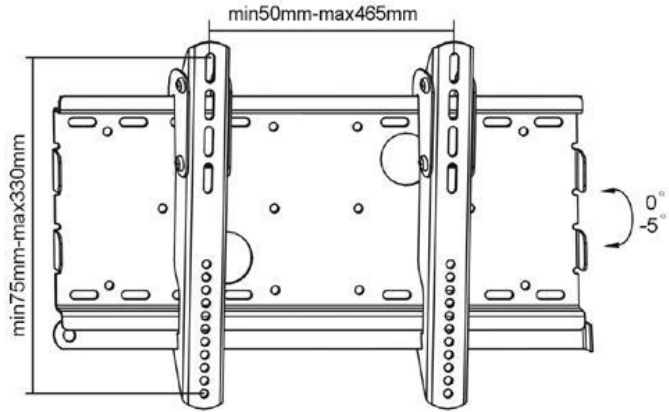
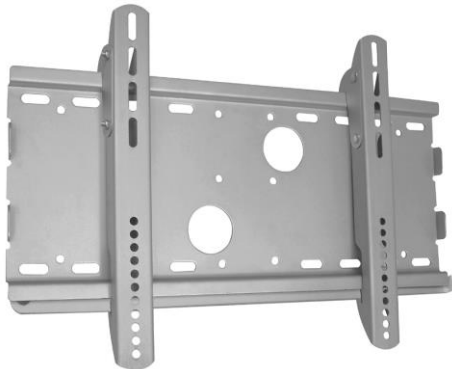

### Product information:

- Universal wall mount for TVs
- Max loading weight 75 kg
- 23 – 40“ (85 -102 cm)
- Vesa: max 400x200
- Wall distance: 34 mm
- Tilt: -5°
- Stable and solid design
- Anti Theft System

Art.Nr.: 23081 (silver) and 23086 (black)  
 EAN: 4005039230813 (silver) and  
 4005039230868 (black)

Specifications subject to change without notice.



**reflecta gmbh**

Merkurstrasse 8  
 D 72184 Eutingen

Phone: +49 (0) 7457 9465-60

Fax: +49 (0) 7457 9465-72

e-mail: [mail@reflecta.de](mailto:mail@reflecta.de)

http: [www.reflecta.de](http://www.reflecta.de)